



FACT SHEET

SE92

Seismic 500E Grade Mesh

2440 mm x 6100 mm (12.76m² nett cover)

COMPLIES WITH THE REQUIREMENTS OF AS/NZS 4671:2001 AND WITH NZS 3604:2011

TEST CERTIFICATES AVAILABLE

All sheets are individually numbered to ensure accurate identification

WIRE SIZE	9.0mm DIAMETER	MIN. UNIFORM ELONGATION	10%
WIRE MASS	0.499kg/m	YIELD STRESS	≥ 500 Mpa 159 kN/METRE WIDTH
CROSS SECTIONAL AREA	318 mm ² /METRE WIDTH	RATIO Ultimate / Yield	≥ 1.15
MASS PER SQUARE METRE	4.994 kg/METRE ²	MINIMUM WELD SHEAR	1623 kg force

Side and End Lapping

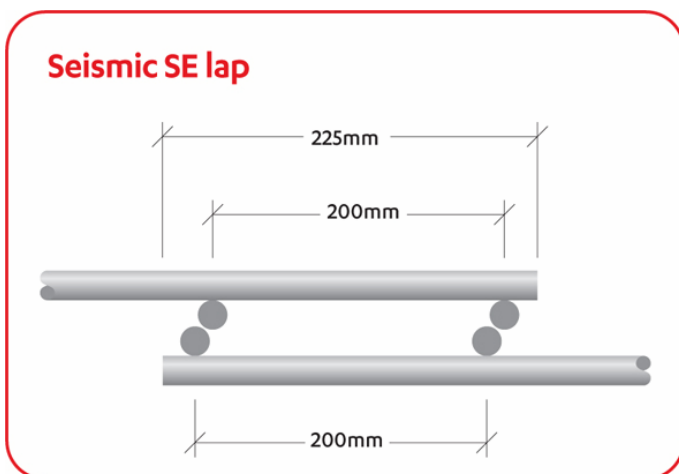

The Lap splices listed on this chart are based on NZ Standard 3101 requirements and Steel & Tube Wire Processing believe that most design situations will be satisfied, however, no responsibility for design accuracy can be assumed and designers should refer to NZ Standard 3101:2006 for substantiating calculations.

PLEASE NOTE:

Compliance with this lap splice ensures the requirements of NZS 3604:2011 will also be met.

To talk with an expert, call us today on **0800 478 335**
Or find out more online at www.steelandtube.co.nz

(OCT 2011)

